



TELEDYNE OPTECH
Everywhere you look™

Part of the Teledyne Imaging Group



POLARIS Laser Scanner

Compact, Powerful Scanning Technology from Teledyne Optech

The **Optech Polaris Terrestrial Laser Scanner (TLS)** delivers accurate, precise data faster than ever before, bridging the gap between small, light-weight, short-range sensors and large, long-range, pulsed time-of-flight scanners. Built with surveyors in mind, the Polaris has a user-friendly on-board operator interface with menu-driven operations for quickly collecting and georeferencing point cloud data.

With a powerful quad-core processor, an integrated high-resolution camera, a digital compass and inclinometer, an L1 GNSS receiver and weather-proof housing, the Polaris can be deployed in various environments for a wide range of applications, using different workflows and setups. The Polaris leads the market in price versus performance, starting at a price that rivals short-range scanners while outperforming long-range scanners. With accelerated performance and all the built-in features surveyors need, the Polaris offers more flexibility than ever before. Whether on a tripod, vehicle, or moving platform, the outstanding performance of the Polaris makes it the most versatile and efficient terrestrial laser scanner on the market.

www.teledyneoptech.com



APPLICATIONS

- » Civil Engineering
- » Construction
- » Transportation
- » Mining
- » Architecture
- » Archaeology & Cultural Heritage
- » City Modeling
- » Geology
- » Industrial & Marine
- » Forensics
- » Forestry
- » Entertainment – Virtual Reality
- » And many more...



SENSOR FEATURES

- » Long-range capability
- » High-speed data acquisition
- » 100% scanning efficiency
- » Wide, selectable field of view
- » Multiple lidar returns
- » Internal cameras
- » External camera option

HARDWARE FEATURES

- » Weather-proof housing
- » Internal data storage
- » Internal hot-swappable batteries
- » Flexible external powering options
- » Tilt compensation
- » L1 GNSS receiver
- » Digital compass
- » Large, bright, on-board touchscreen
- » Laser plummet?

SOFTWARE FEATURES

- » Remote operation capability
- » Project planning
- » Direct georeferencing in the field
- » Automatic target recognition
- » Automatic target-free registration
- » Easy upgrades
- » Powerful bundled ATLAScan software

The Polaris Family:

Versatile Capability for Diverse Data Capture Applications



POLARIS	HD	ER	LR
SYSTEM PERFORMANCE	High-speed, short-range mode (up to 250 m) for indoor and some outdoor applications	Adds mid-range mode (up to 750 m) for more applications	Adds long-range mode (>2000 m) to cover all applications
Laser repetition rate	500 kHz	200 kHz	500 kHz
Max range capacity @ 90% reflectivity	250 m	750 m	250 m
Max range capacity @ 20% reflectivity	125 m	400 m	125 m

MAXIMUM RANGES vs REFLECTIVITIES

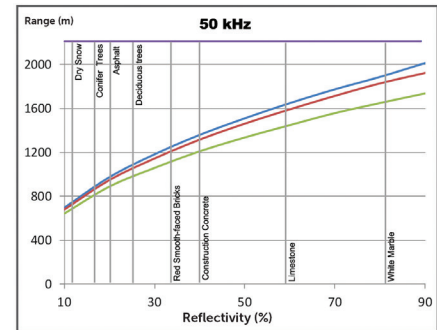
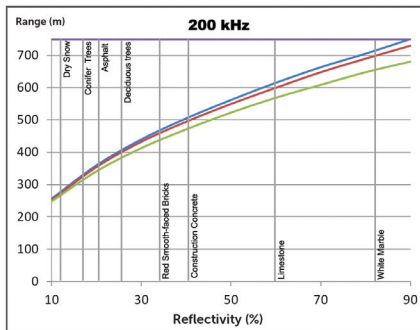
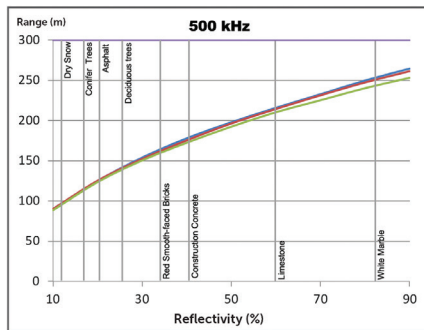

Short-range applications

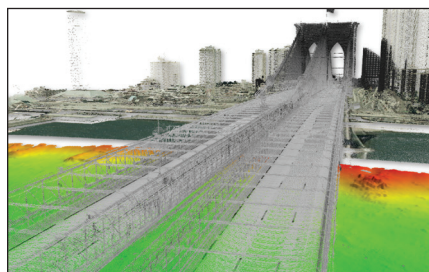



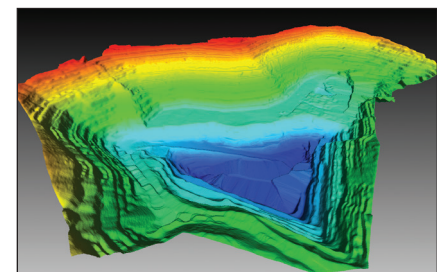





Mid-range applications



Long-range applications

Polaris Customization Options:

Along with the different models there are also a wide range of options, so you can build your **Polaris** around your current requirements and upgrade whenever you need to!

	<p>Sensor Package: Includes internal GNSS, L1 GPS+GLONASS receiver, digital compass, and dual-axis inclinometer ($\pm 30^\circ$ range of operation with accuracy of 0.01°).</p>
	<p>Internal Camera Package: Includes two fully calibrated internal cameras (5 Mpix each) to automatically colorize the point cloud and generate 80-Mpix panoramic images.</p>
	<p>External Camera Package Option: Includes calibrated Nikon D5600 24.2-Mpix DSLR, camera mount, set of lenses, and connecting cable for automatic camera triggering. Other cameras can also be used. Consult Teledyne Optech for more information.</p>
	<p>L1/L2 GNSS Option: Enables connectivity to an external GNSS receiver. Includes adapter to mount an external GNSS antenna on top of the Polaris.</p>
	<p>Batteries: Rechargeable smart lithium-ion battery pack, hot swappable, 2.5 hours of continuous survey time. Batteries are safe for air transportation, being <100 Wh each.</p>
	<p>External Power Unit: Accepts 9–32 V DC power. (compatible with 12-V DC automotive jacks)</p>
	<p>Target Set: Specially designed to be automatically detected by any Polaris system. Used for georeferencing in the field via backsighting or resection workflows.</p>
	<p>External GNSS/ Prism Mount: Mounts any external GNSS antenna or regular surveyor prism on the top of Polaris.</p>
	<p>Mobile: Enables option to use Polaris on a moving platform via connection to an external GNSS/INS unit.</p>

Make Every Shot Count with the Polaris!

Most laser scanners use mirrors constantly rotating in a full vertical 360° circle to cover the vertical field of view (FOV). The key to the efficiency of the Polaris is its galvanometric oscillating mirror that allows the user to completely adjust the scanning FOV, focusing only on what really needs to be scanned. In fact, the user can define multiple regions of interest³ (ROI) with different scanning resolutions in the same scan. No more excessive FOV, no more wasted laser shots, no more losing time in the field and in the office processing data that you don't need. Just get exactly what you need at the right resolution.

Boost your scanning efficiency to 100% with the **Polaris**.

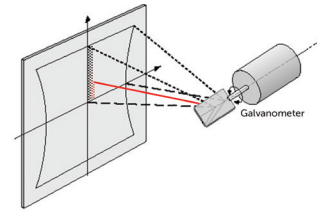

The galvanometric oscillating mirror allows for accurate FOV selection with 1° resolution.

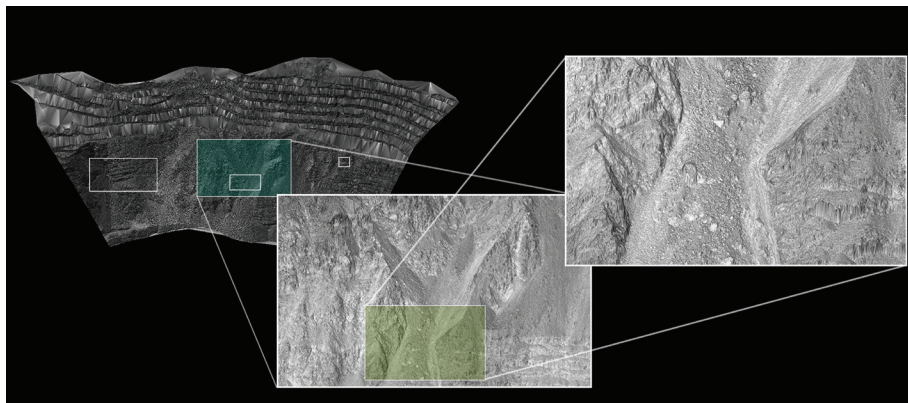

Selecting multiple regions of interest (ROIs) with different resolutions in a single scan.



By focusing its sensor on a 2°x2° ROI, the Polaris captured this cross at 96 meters distance in 2 minutes with ultra-high resolution (3D mesh of the Kaiser Wilhelm Memorial Church, Berlin, Germany).

Waveform Analysis

To maximize its performance, the Polaris analyzes both the analog and digitized waveform of the return signal. The Polaris measures multiple ranges from the raw analog signal to obtain the best accuracy. The intensity of each return is measured by digitizing the signal waveform. Using only the digitized waveform degrades accuracy due to additional range errors introduced by the digitization process.

Recording Multiple Objects

The Polaris can collect up to four returns from each laser pulse, including the first two and last two returns. This is particularly useful when scanning objects that do not completely block the beam, because the Polaris can capture both the blocking object (such as a tree) and the object behind it (such as a wall) with a single laser pulse.

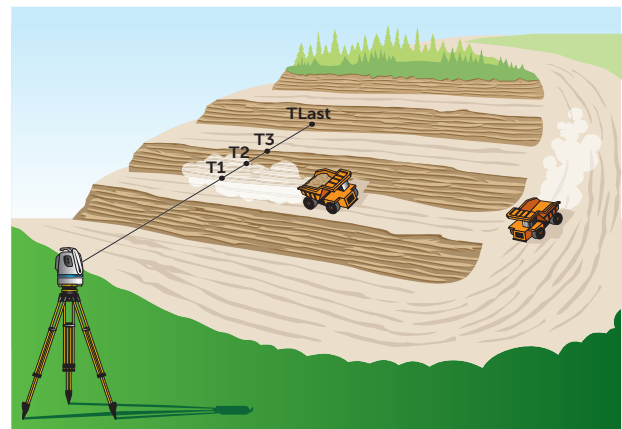
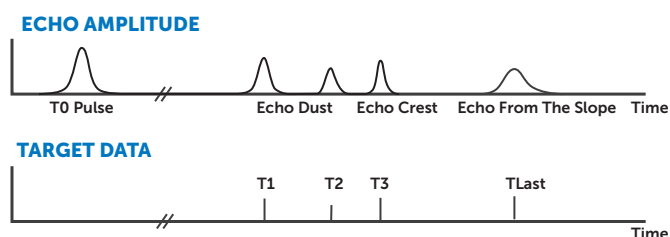

Polaris Stop&Go Workflow

The Polaris Stop&Go workflow greatly accelerates large-scale data collection. By mounting the sensor on a vehicle and controlling it remotely using the ATLAScan Control module, the user can quickly stop, survey, and move to the next survey area. Whether using the Polaris on a tripod, installed on the roof the car, or lifted up to 6 meters high, the Stop&Go methodology lets you execute multiple surveys in rapid succession to cover wide areas from multiple perspectives.

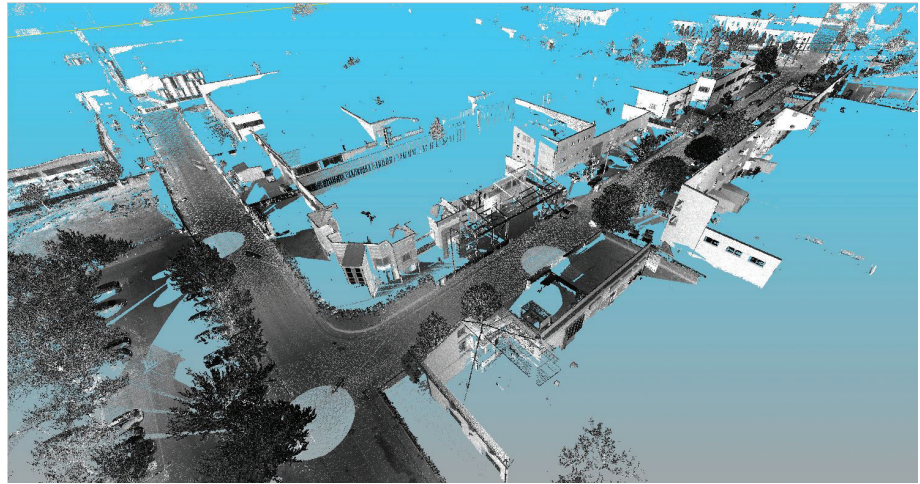

Polaris Mobile

The Mobile options lets users survey from a moving platform such as a car or a boat by connecting the Polaris to selected external GNSS/INS units. This effectively converts the Polaris into a mobile scanner that can collect data for marine applications, corridor mapping or complex stockpile surveys, and directly output georeferenced point clouds. The Polaris collects 54 vertical lines of data per second, resulting in well-spaced data even when the vehicle is moving quickly. It can also reduce its field of view to increase the survey speed.

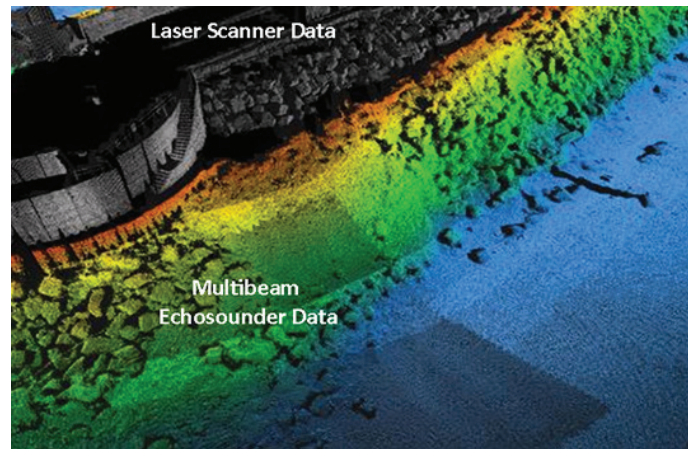



Polaris... Simplified, Touch Screen, Menu-Driven Operation

The Polaris is a stand-alone terrestrial laser scanner that is typically operated via an on-board, sunlight-visible touchscreen. Its on-board user interface is available in English, Chinese, Spanish, German, Japanese, Italian, Russian, and several other languages.

Scans are performed via easy-to-use menu-driven prompts, with data stored locally on the Polaris. After the scan, data is transferred to a Windows-based computer for further processing.

Alternatively, you can operate the Polaris via computer, giving you in-depth control and more visibility into scan parameters. The scan data is then stored on the computer for immediate processing, using project-based software features.

GRAPHICAL TOUCH-SCREEN:

- » Sunlight-visible
- » Resistive single touch
- » 640 x 480 pixels
- » Color TFT LCD

Polaris Remote Control

For greater convenience, operators can control the Polaris remotely via a wired (Ethernet) or wireless connection to a laptop or tablet running the ATLAScan Control module. This provides full control of the scanner, as well as advanced scanning options including georeferencing tools. ATLAScan can even transfer the survey data directly to the controlling device, so the user can operate the scanner via the Internet from anywhere in the world and download its data directly or transfer it to a cloud server.

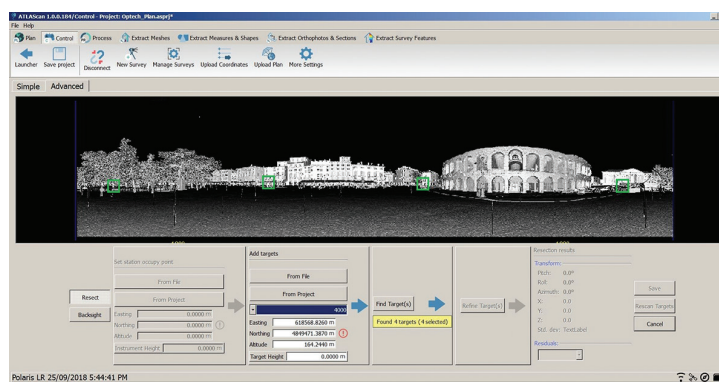

Scan Like a Surveyor



The Polaris is designed for use in a standard surveyor's workflow, much like a total station, incorporating common practices such as:

- » Setting up the instrument on a known point using a tripod, a tribrach
- » Leveling the instrument using the electronic bubble in its on-board user interface
- » Performing on-site georeferencing by backsighting or resection (free station) using automatically recognizable targets.

The field georeferencing information is recorded together with the scan data, so the point clouds are directly aligned and georeferenced as soon as they are loaded into ATLAScan. Processors can refine the registration even further using ATLAScan's advanced alignment and georeferencing algorithms.

To facilitate the workflow, the Polaris and its targets have the same tribrach-to-reference-center height as the majority of total stations (196 mm). This makes it easy for a surveyor to incorporate the Polaris into their activities by using the same tribrach for the Polaris, a total station, or a target.

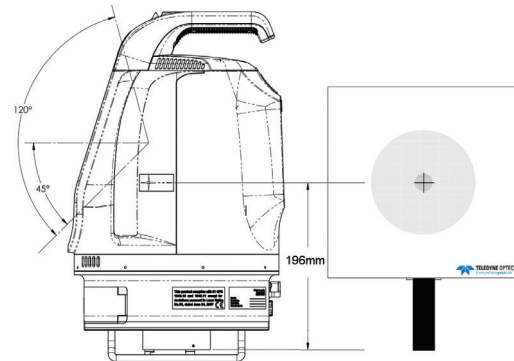
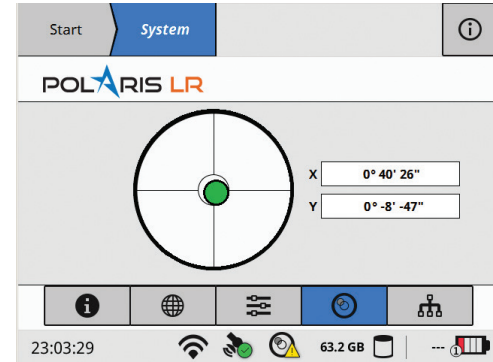

Polaris Targets – RetroID™

The Polaris's powerful RetroID™ technology automatically detects and labels targets in the field at ranges up to 100 m, measures their centroids, performs georeferencing calculations (backsighting or resection), and presents the residuals on the touch screen for evaluation.

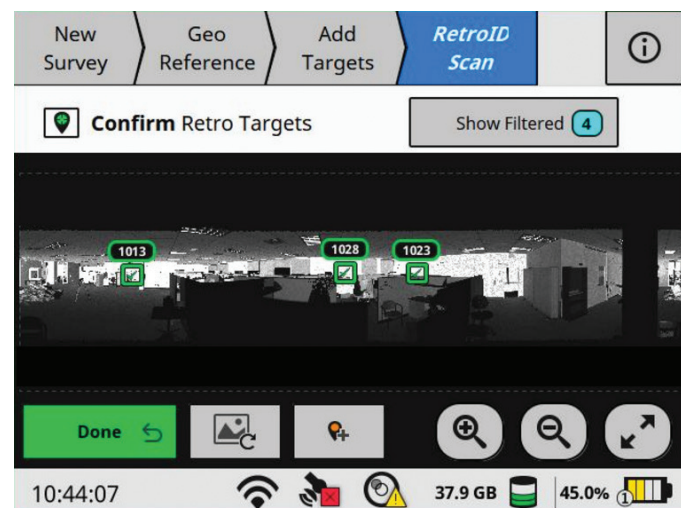

Plan at the Office – Execute Automatically in the Field

Preparation at the office

ATLAScan's Plan module allows the user (usually an experienced surveyor) to plan a 3D scanning survey that a less-experienced operator can automatically execute in the field. Using a background map of the area, the planner defines the scanning positions and georeferencing targets either manually or by loading a list of existing points, and sets all of the survey parameters to be used at each location (georeferencing method and targets, Polaris range mode, resolution, FOV, and more). The whole plan is saved and then uploaded to the Polaris for execution.

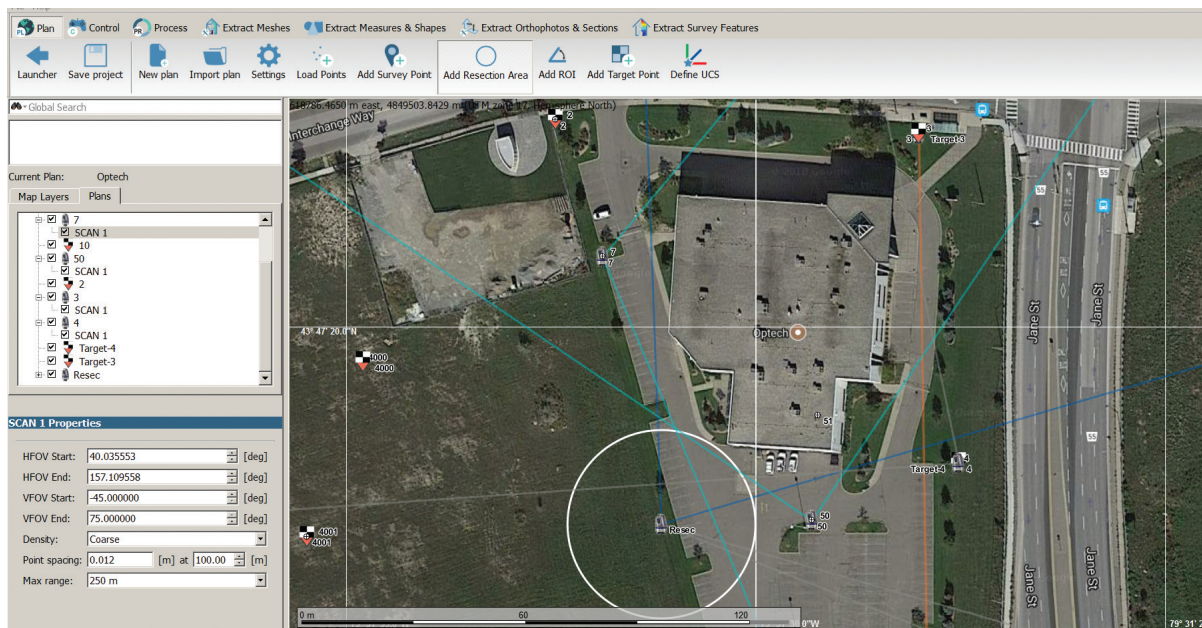

Automatic execution in the field

In the field, the surveying workflow is highly automated. Once the Polaris is in position, the operator can execute the plan. The Polaris uses information from its internal sensors (GNSS and compass) to guide and assist the operator, setting the scanning locations, options and parameters for the survey as planned at the office, ensuring that the survey will be properly performed. However, if circumstances in the field require a change of plan, the operator still has the flexibility to deviate from the planned settings as needed.

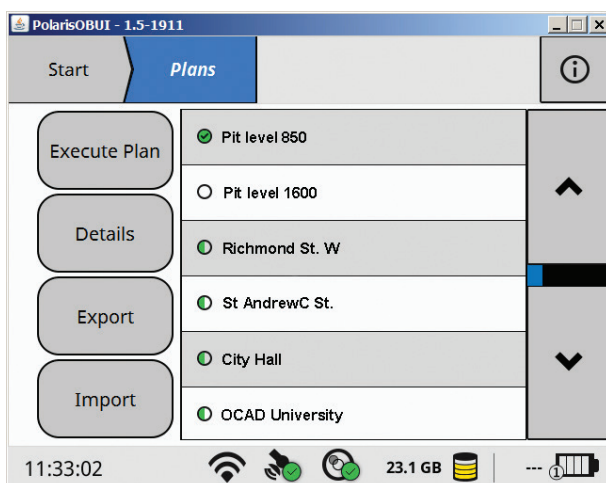

Polaris ATLAScan



The Polaris **ATLAScan** software suite is a field-proven, Windows-based workflow platform that enables step-by-step operation for any 3D laser scanning survey, from planning the survey to importing field data to generating final deliverables.

ATLAScan:

- » Manages all data associated with a scan project, including point clouds, imagery, sensor data, control points and coordinate conversions, as well as deliverables such as meshes, 3D models, primitives and measurements.
- » Incorporates high-end functionalities like automatic target-free registration, bundle adjustment, automatic target detection and matching, advanced georeferencing workflows, primitive fitting and more.
- » Minimizes processing steps and optimizes functionality, using wizards and other advanced tools to help the user shorten processing times and improve productivity.

ATLAScan's packages

Works	The basic package, bundled with every Polaris scanner, includes project planning, remote Polaris control, point cloud processing, and advanced registration and georeferencing.
WorksPro	Provides higher-level deliverables such as feature extraction, meshing and 3D modeling, in addition to all the functions of Works.
Photo	Enables manipulation of external cameras and integration of imagery onto the point cloud, in addition to all the functions of WorksPro.
Mobile	Supports the use of Polaris as a mobile system in combination with a GNSS/INS system, in addition to all the functions of the main package.

ATLAScan's modules

Plan	Allows the user to plan a 3D scanning survey at the office that a less-experienced operator can automatically execute in the field.
Control	Remotely controls a Polaris connected via wired (Ethernet) or wireless connection. Features all options available through the on-board interface of the Polaris, as well as more advanced capabilities. Remote operation is particularly useful when using the Polaris in Stop&Go setups where the on-board interface is not accessible, but can be used for any setup at the convenience of the operator. Its complete functionality is available in the basic Works package.
Process	Provides a wizard-based step-by-step workflow to import, pre-process, align and georeference point cloud data and camera imagery. Features powerful, automatic, target-free pre-registration and bundle adjustment algorithms and various versatile georeferencing workflows. Its complete functionality is available in the basic Works package.
Extract	Features several post-processing and analyzing tools to extract information and deliverables from point cloud datasets. Includes feature extraction, meshing, 3D modeling, classification, vegetation removal, advanced point cloud colorization, external camera imagery calibration and draping, orthophoto creation, measurements, area and volume calculations, inspection and tunneling tools and more. The exact tools available depend on the ATLAScan package.

Polaris ATLAScan - Key Features

Target-free automatic alignment

A powerful pre-registration algorithm provides the capability to register point clouds without any reference from the field whatsoever: No targets, no coordinates, and no tie-points are needed⁵. Intermediate evaluation of the result by the user is optional, allowing for a reliable alignment solution even for very large datasets consisting of hundreds of scans with minimal user intervention.

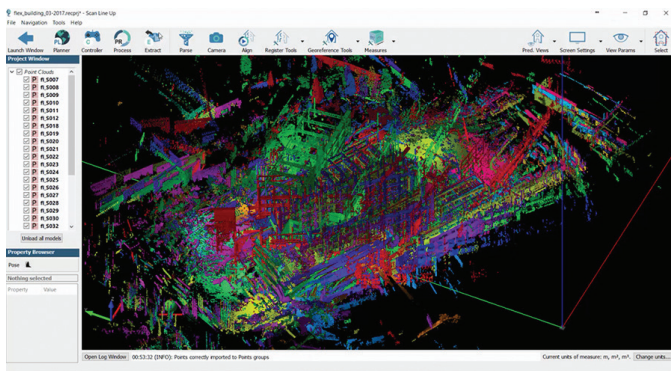

Point cloud before alignment.

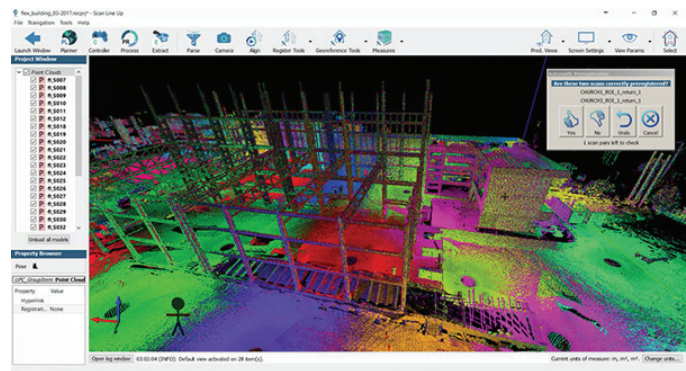

Point cloud aligned automatically using only data from the Polaris compass, inclinometer, and GNSS.

Bundle adjustment

Performs the final alignment of a group of connected and overlapping scans using an advanced bundle adjustment algorithm, thus ensuring the best possible combined solution, even for very large datasets with many connecting scans.

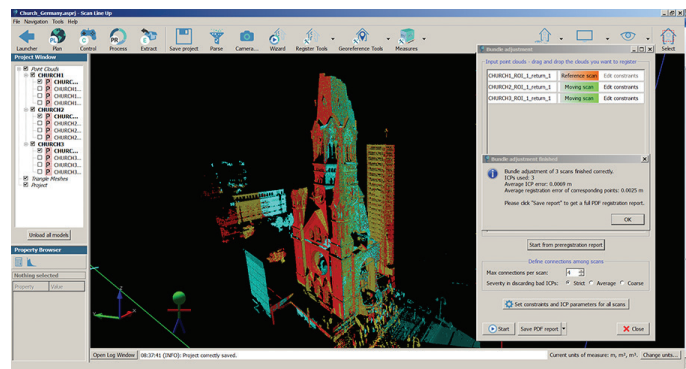

Vegetation classification and removal

ATLAScan's powerful filtering and classification algorithms use its multiple-return recording capability to automatically classify and remove vegetation, resulting in clean object surfaces for further processing and analysis.

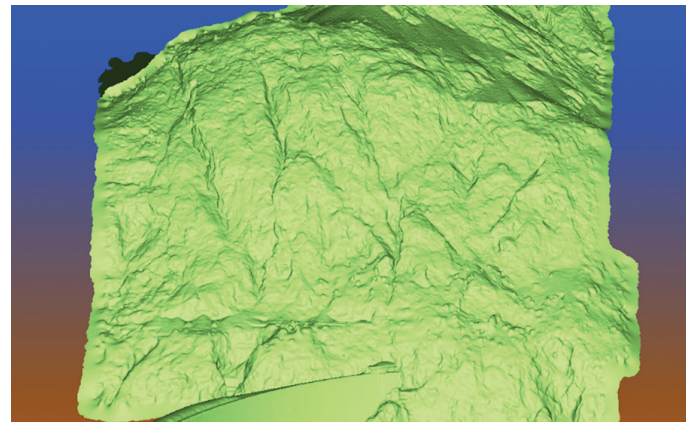

Polaris ATLAScan - Key Features

Import and work with any point cloud at no extra cost

ATLAScan is not limited to Polaris data, but can import point cloud data from any sensor in the market, from handheld to long range scanners or even UAVs, and combine it all in a single project. This makes it a universal and complete point cloud processing solution for every user's needs. ATLAScan can import PTS, LAS, TXT, E57, CSV, ASC, SCAN, and PLY point cloud formats, as well as 3DS, TXT, DAE, OBJ, DXF, PLY, PLY, IFC, STL, and WRL mesh model formats.

Exporting final deliverables

ATLAScan brings much more than accurate alignment and georeferencing of point clouds. Users can transform the raw data into real products ready for delivery, including terrain and 3D meshes, contours, sections, area and volume calculations, change detection reports, ortho-images, videos, automatic line feature extractions⁶ and more. Deliverables are available for export in a wide range of commonly used digital formats for point clouds, meshes and CAD objects.

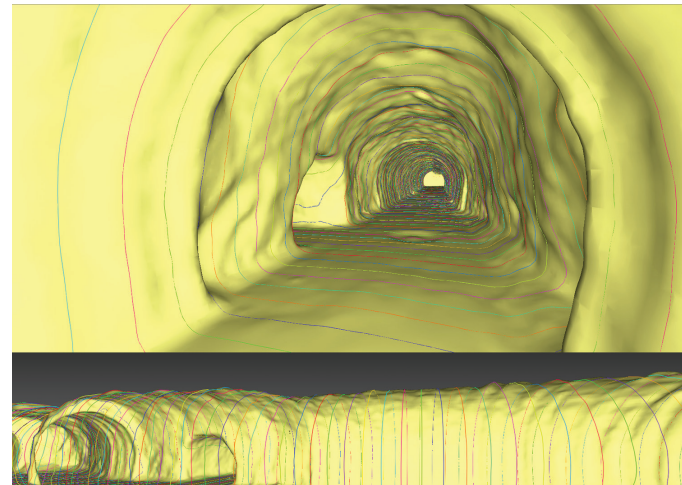
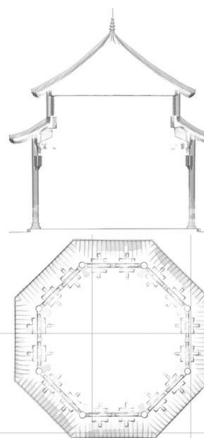
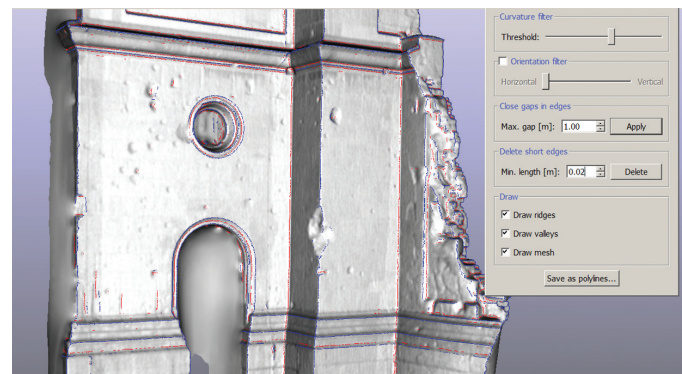
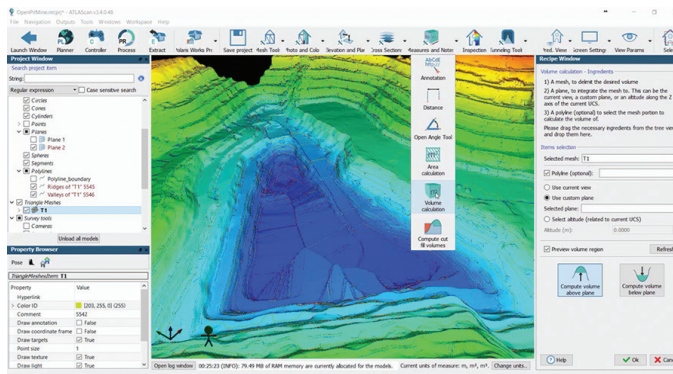

Permanent license and viewer mode

ATLAScan comes with a perpetual license, meaning no surprises or extra charges for renewals. Furthermore, the software can run without a license in viewer mode to view already processed ATLAScan projects.

Polaris ATLAScan - Key Features

ATLAScan Monitoring Solution

The optional ATLAScan Monitoring Solution is a complete solution for continuous, real-time monitoring of mines, landslides, glaciers and any other deforming surface of critical importance. This web-based application remotely controls the Polaris, schedules its continuous operation, and processes and compares the data in real time. The user can define multiple change thresholds for the data, each with their own alarm level, so that ATLAScan triggers the appropriate alarm if the data crosses a threshold.

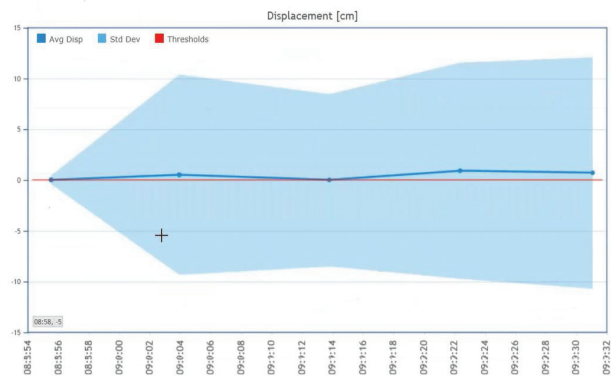
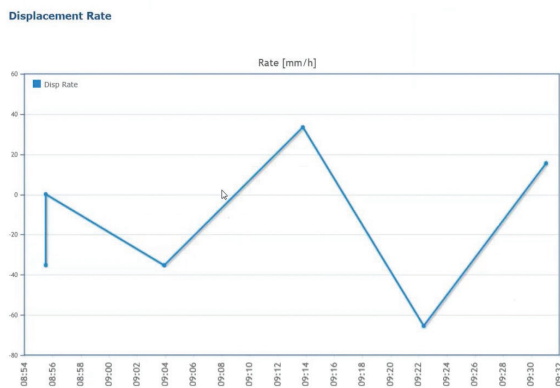
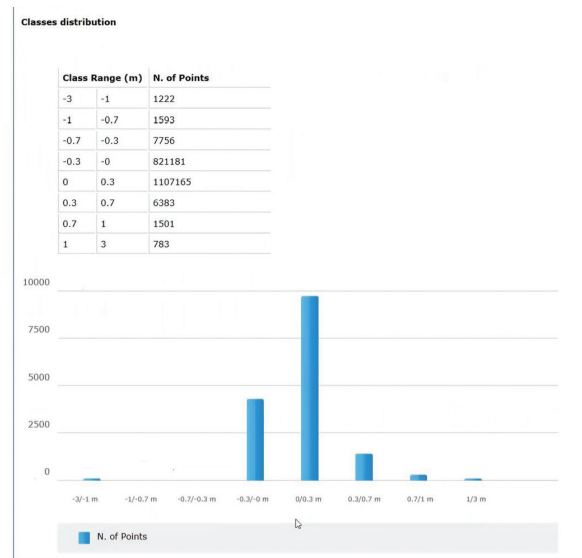
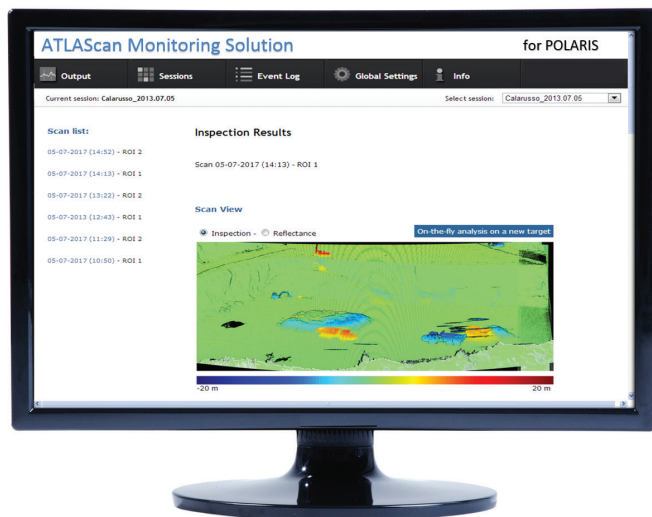

Training and Support

Best-in-class training material and programs are available to Polaris users, focusing not only on the hardware and software but also on surveying strategies and advanced workflows to prepare our clients for real-world applications. Teledyne Optech's reputable technical support service is likewise prepared to promptly address our clients' requirements and needs.

► Polaris TLS - Operation elements and connectors

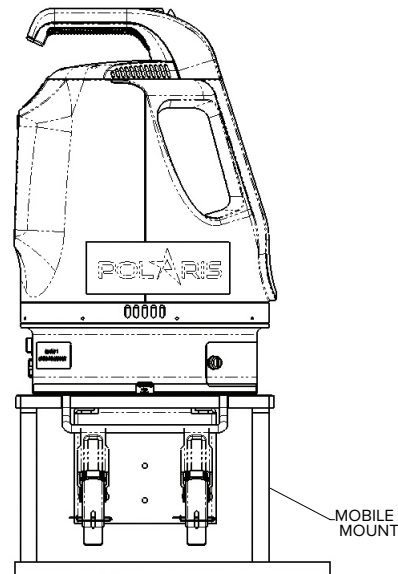
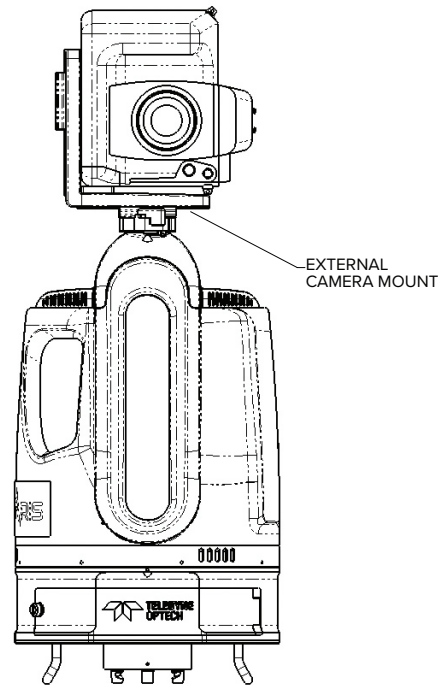
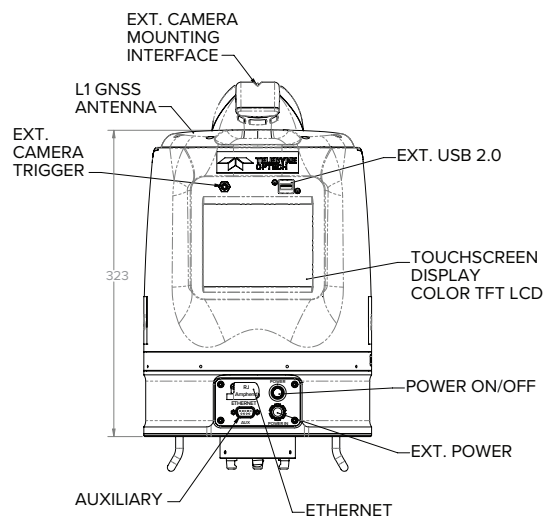
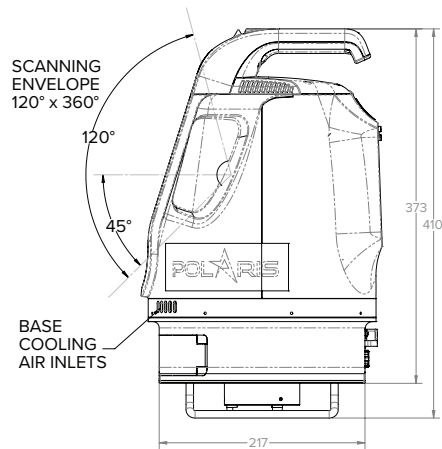
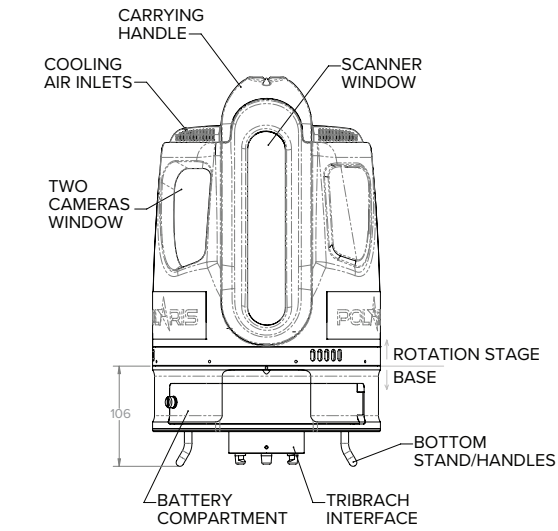

COMMUNICATION AND INTERFACES

- » LAN Port 10/100 Mbit/Sec
- » Integrated WLAN interface
- » USB port 2.0
- » Connector for GNSS antenna
- » Connector for external GNSS receiver and synchronization (1PPS)
- » Internal 250-GB SSD

Specifications

Laser

Range measurement principle	Pulsed
Wavelength	1550 nm (invisible)
Laser safety classification	1 ²
Sample collection rate	Up to 2 MHz
Intensity recording	12 bits
Minimum range	1.5 m
Waveform digitizing technology (WFD)	Yes
Number of returns recorded	Up to 4 (first 2 and last 2)

Scanning Resolution

Angular measurement resolution	up to 12 µrad
Max. sample density [point to point spacing]	2 mm @ 100 m

Accuracy and Repeatability

Range accuracy (1 sigma)	5 mm @ 100 m
Range resolution	2 mm ⁸
Precision, single shot (1 sigma)	4 mm @ 100 m
Angular accuracy	80 µrad

Scanning Characteristics

Max. field of view (vertical)	120° (-45 to +70°)
Max. field of view (horizontal)	360°
Min. angular step size (vertical)	12 µrad
Min. angular step size (horizontal)	20 µrad

Additional sensors and features

Dual-axis inclinometer (accuracy)	Up to 0.01°
GNSS receiver	L1 GPS + GLONASS
External GNSS support	Yes, incl. antenna mount
Compass	Digital
Registration/orientation method	GNSS and compass, backsighting, resection
On-board registration data	Yes ⁴
On-board target acquisition RetroID	Yes
Pause while scanning	Yes
Multiple scan area selection	Yes, multiple ROIs ⁵
On-board planning mode	Yes
Mobile operation	Yes

System Peripherals

Data storage capacity	250 GB internal SSD
-----------------------	---------------------

Communications / Data transfer

Wireless LAN	Yes
USB connector	Yes
Ethernet port	Yes
Communications/data transfer	100Mbit Ethernet, WLAN, USB



All specifications are subject to change without notice.

Imaging system

Internal cameras	Yes
Internal camera resolution	80-Mpix panoramic image
Export format of internal camera	JPEG
External camera DSLR	Yes with auto trigger
White-balancing DSLR	Yes
Export format of ext. camera	JPEG, NEF

Power

Power supply input voltage	9 to 32-V DC
Battery type	Internal, hot swappable Li-Ion batteries
Battery power	2.5 hours
Power consumption	60 W

Operation Characteristics

Operating temperature (min.) ⁹	-20°C (-4°F)
Operating temperature (max.)	+50°C (122°F)
Protection Class	IP64
Storage temperature	-40°C to +80°C (-40°F to +176°F)

Physical Characteristics

Height	323 mm (12.7")
Width	217 mm (8.5")
Total weight	11.2 kg (24.6 lbs.)

Control Options

On-board display	Touchscreen control, sunlight visible, 640x480, color
External user interfaces	Tablet, PC

ATLAScan software

Remote scanner control	Yes
Geo-referencing	Automatic
Target-free automatic alignment	Yes ⁵
Feature / primitive extraction	Yes
Terrain mesh	Yes
3D meshing	Yes
Measurements and calculations	Yes
Monitoring	Yes
Automatic line features extraction	Yes ⁶
Vegetation removal	Yes

¹ Max range tested on flat targets, larger than the laser beam diameter, perpendicular angle of incidence and STD Clear visibility (23 km).

² Complies with 21 CFR 1040.10 and 1040.11 except for deviations pursuant to Laser Notice No. 50, dated June 24, 2007.

³ Definition of multiple ROIs in a single scan is possible using ATLAScan Control module

⁴ Using the on-board georeferencing functionality

⁵ Successful pre-registration depends on the object geometry, scanning resolution and overlap (min. 20%) between different scanning positions.

⁶ Automatic line extraction for break lines of a mesh (e.g. crests and toes of a terrain mesh).

⁷ Laser plummet is built into the tribrach

⁸ Minimum distance that the Polaris is able to separate two range measurements on objects in a similar bearing.

⁹ Normal operation to -10°C, extended cold temperature operation to -20°C with Optech Cold Weather package.

Ordering information

Contact your local Teledyne Optech representative or an authorized Teledyne Optech dealer

Imagine the Possibilities



Office Locations

We have offices across North America, Europe, and Asia. Find details at:
teledyneimaging.com/offices

Contact Us

By email, phone, or surface mail, start at:
teledyneimaging.com/contact

Find a Distributor

Find your local representative at:
teledyneimaging.com/distributors

300 Interchange Way, Vaughan, Ontario, Canada L4K 5Z8
Tel: +1 905 660 0808

 www.teledyneoptech.com



TELEDYNE OPTECH
Everywhereyoulook™

Part of the Teledyne Imaging Group